

THIS DRAWING IS UNPUBLISHED. RELEASED FOR PUBLICATION  
 © COPYRIGHT - R3 ALL RIGHTS RESERVED.

LOC	DIST	REVISIONS			
P	LTR	DESCRIPTION	DATE	DWN	APVD
AF	50	T1	REVISED PER ECR-20-009164	27JUL2020	MK DH

- 1 CONTINUOUS STRIP ON REELS
- 2 MATING TAB THK IS .033-.030.
- 3 WIRE SIZE IS #18-#14 AWG
- 4 INSULATION RANGE IS .120-.170 DIA.

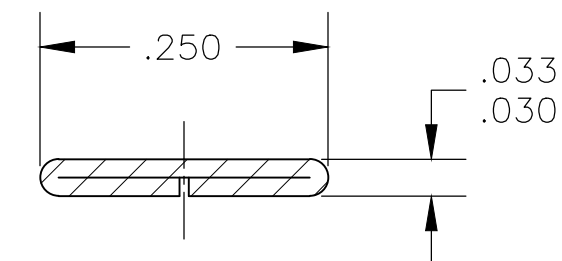
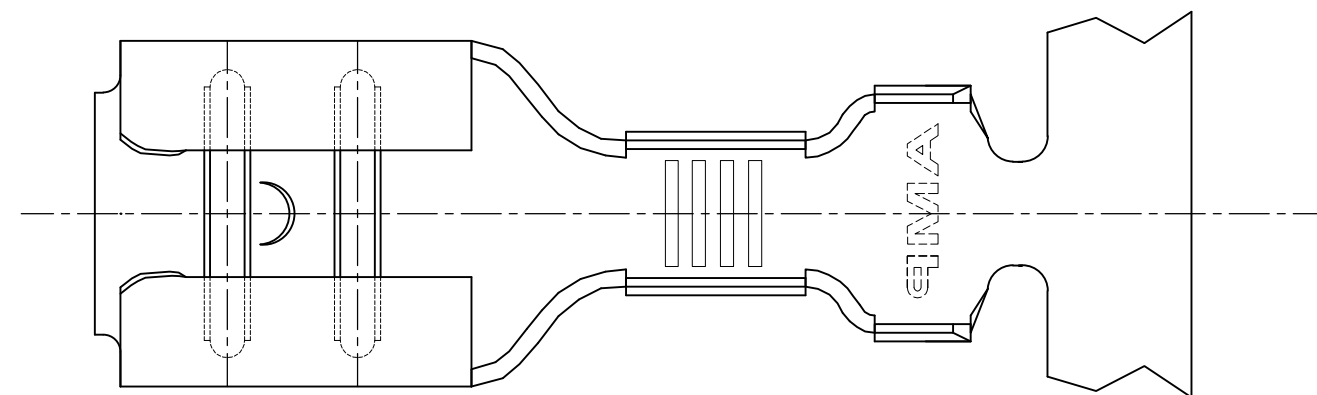

SECTION B-B

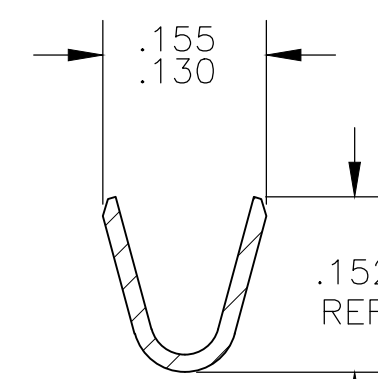
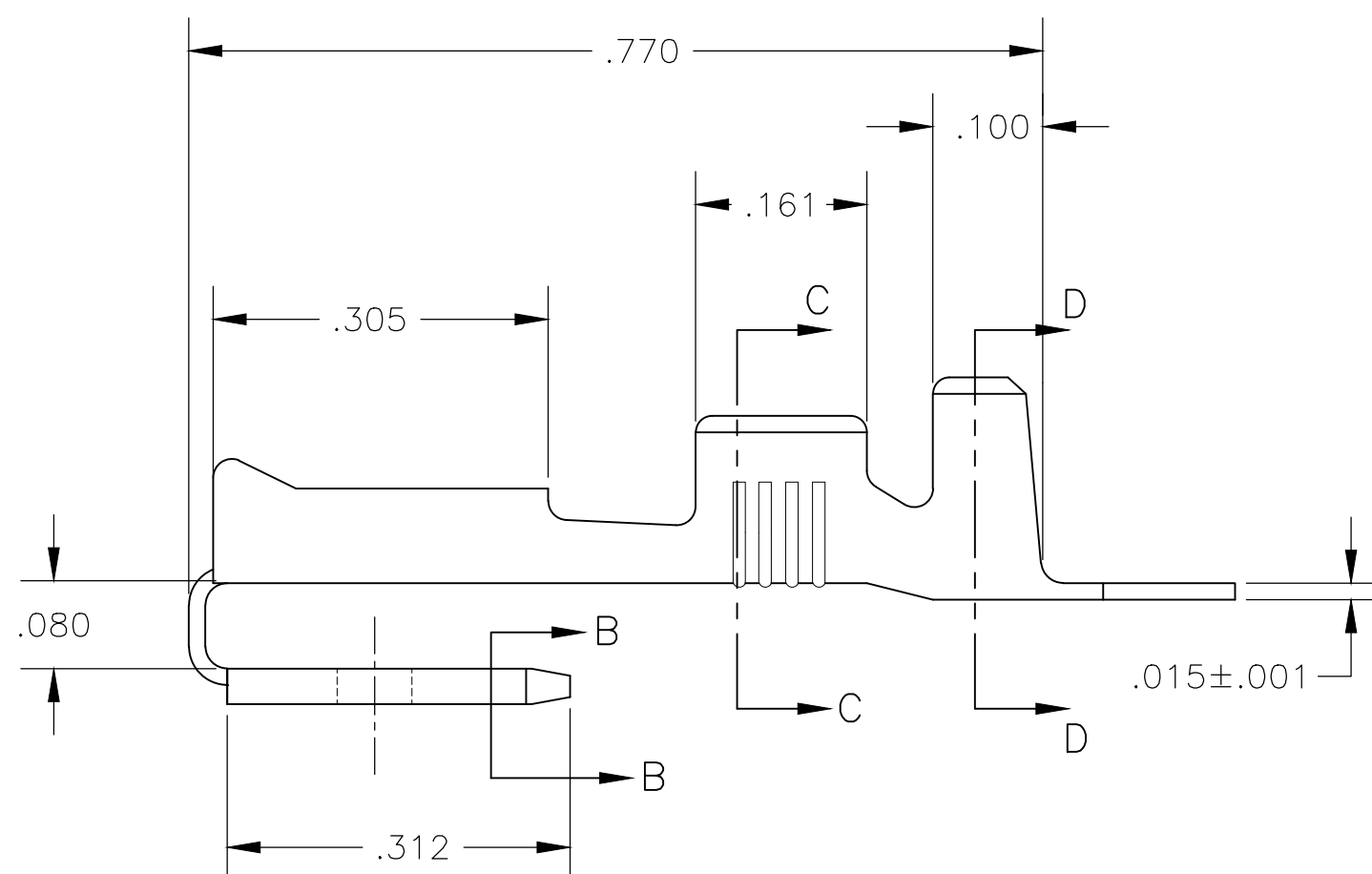

SECTION C-C

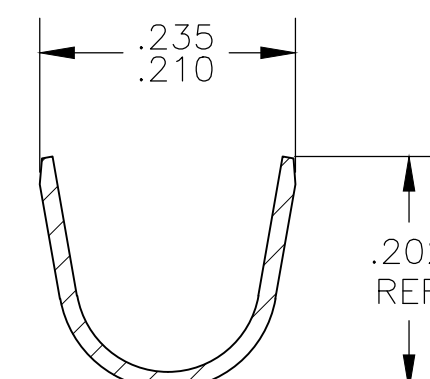

SECTION D-D

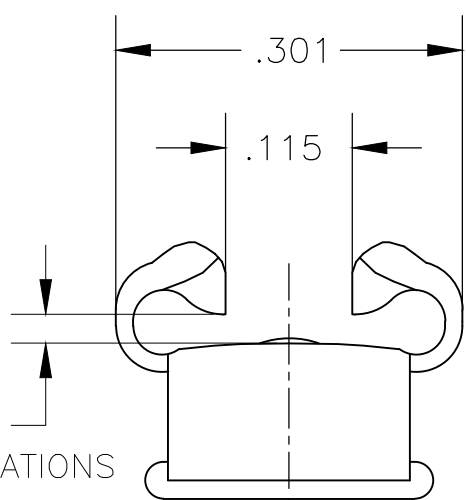

GAP AS REQUIRED TO MEET FORCE SPECIFICATIONS AND .028 MAX

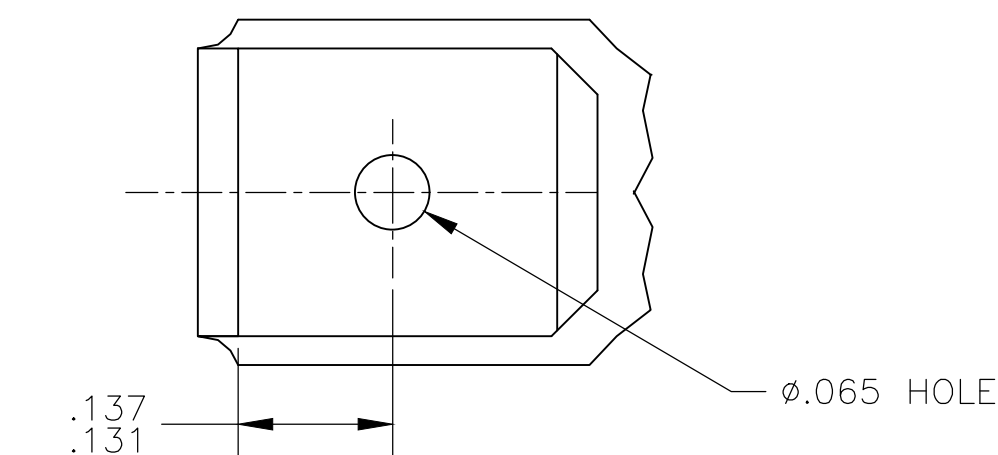

<del>— OBSOLETE</del>	SILVER PLATE	61944-4-
<del>— OBSOLETE</del>	PRE-TIN PLATE	61944-3-
	TIN	61944-2
	—	61944-1
	FINISH	PART NO.

THIS DRAWING IS A CONTROLLED DOCUMENT.		DWN	JR RUTH	26JUL2002	 TE Connectivity
DIMENSIONS: INCHES		CHK	P DESANTIS	26JUL02	
TOLERANCES UNLESS OTHERWISE SPECIFIED:		APVD	P DESANTIS	26JUL02	
0 PLC ± - 1 PLC ± - 2 PLC ± - 3 PLC ± .015 4 PLC ± - ANGLES ± -		PRODUCT SPEC	NAME		
MATERIAL	BRASS	FINISH	SEE TABLE	APPLICATION SPEC	114-2082
CUSTOMER DRAWING		WEIGHT	—	SIZE	A2
		CAGE CODE		00779	DRAWING NO
		SCALE		6:1	SHEET 1 OF 1
		REV		T1	RESTRICTED TO